



Nostalgic AC Parts

"Keeping Your Classics Cool"

BIG BLOCK MOPAR BRACKET SETUP INSTRUCTIONS

(383, 400, 413, 426, 440) WITH OR WITHOUT POWER STEERING

**COMPRESSOR
NUTS BOLTS & WASHERS**



THREE 1/16" SPACERS

LATE W/P
ONE 3/4" SPACER
EARLY W/P
1 1/8" SPACER

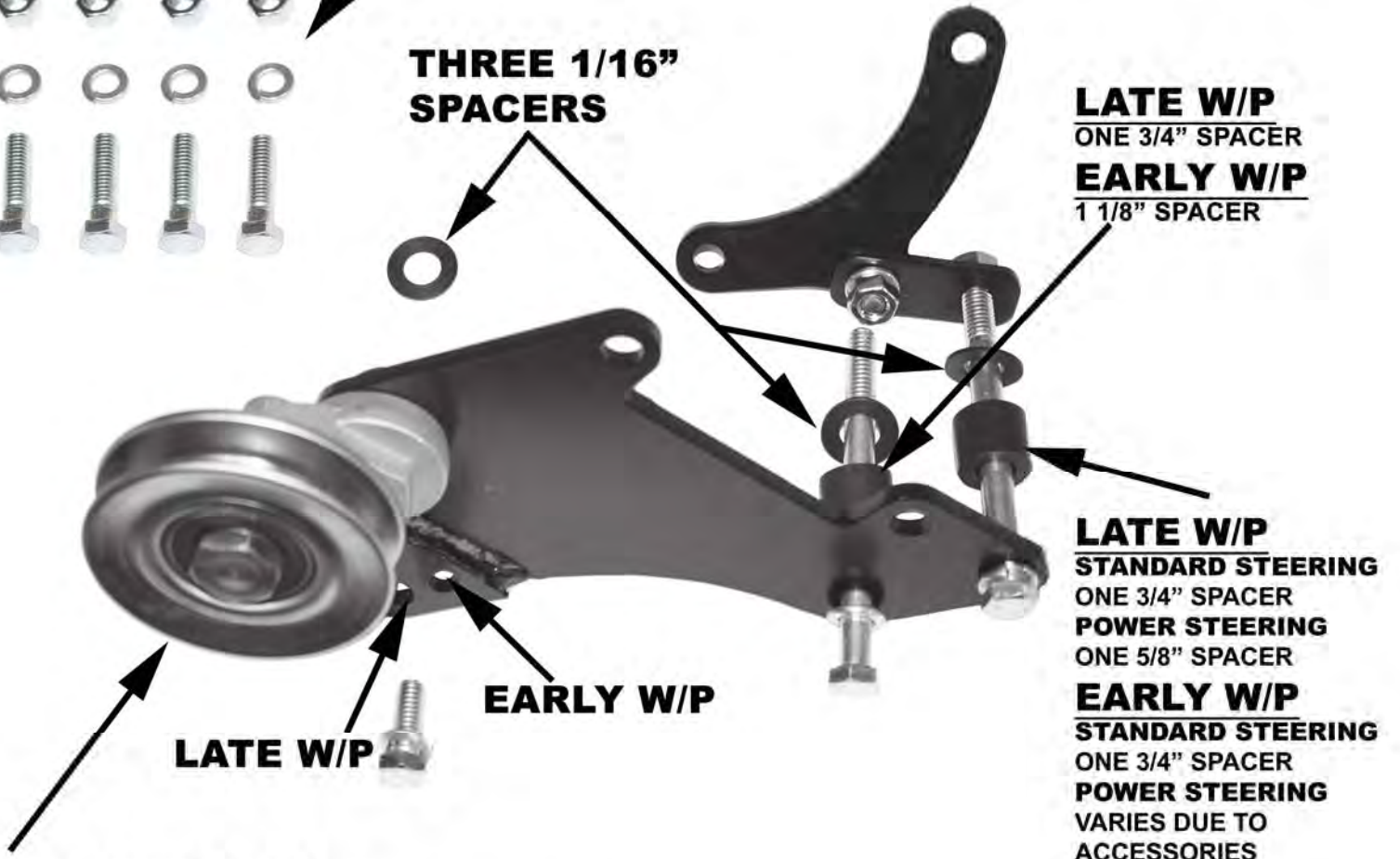

LATE W/P
STANDARD STEERING
ONE 3/4" SPACER
POWER STEERING
ONE 5/8" SPACER
EARLY W/P
STANDARD STEERING
ONE 3/4" SPACER
POWER STEERING
VARIES DUE TO ACCESSORIES

**IF USING IDLER & ECCENTRIC
3-1/2" DEEP CRANK PULLEY IS REQUIRED
(ADD ON PULLEY (PN:PM12) AND FAN SPACER (PN:3960) AVAILABLE)**

REMOVE THESE 3 BOLTS

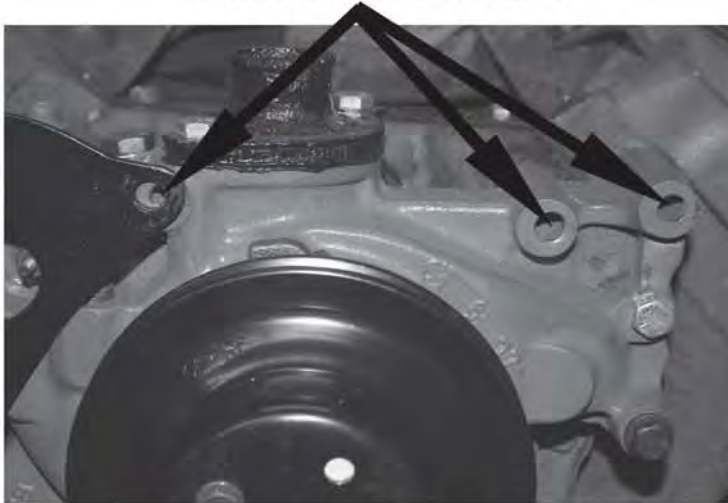

**INSTALL SMALL BRACKET FIRST
 INSTALL 1/2 MOON BRACKET SECOND**

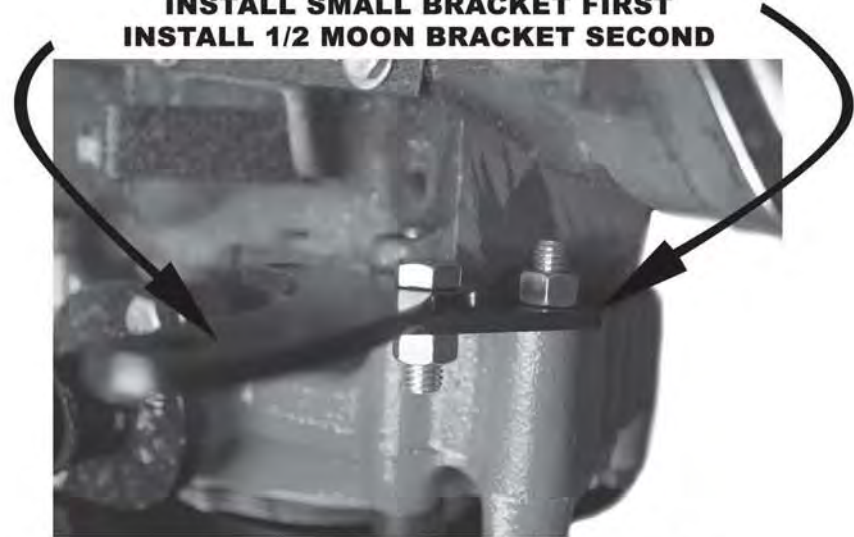

**TWO 1/16" SPACERS HERE
 NOTE: IF NOT USING P/S, USE TWO 3/4" SPACERS**

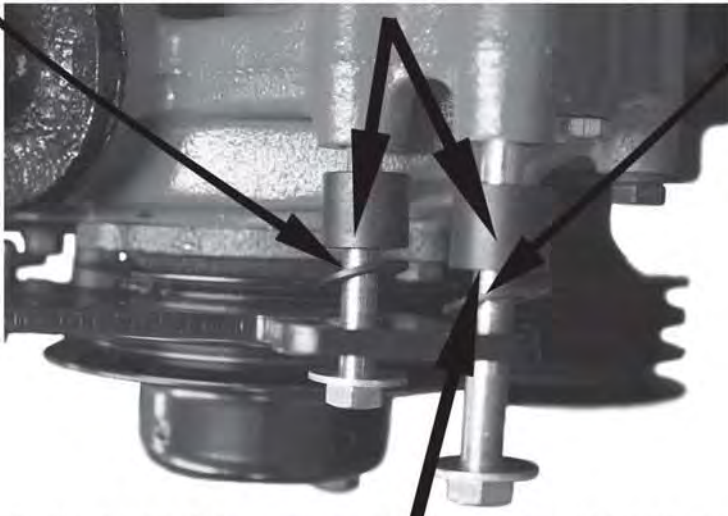

**NEW REAR COMPRESSOR BRACKET
 FACTORY P/S BRACKET**

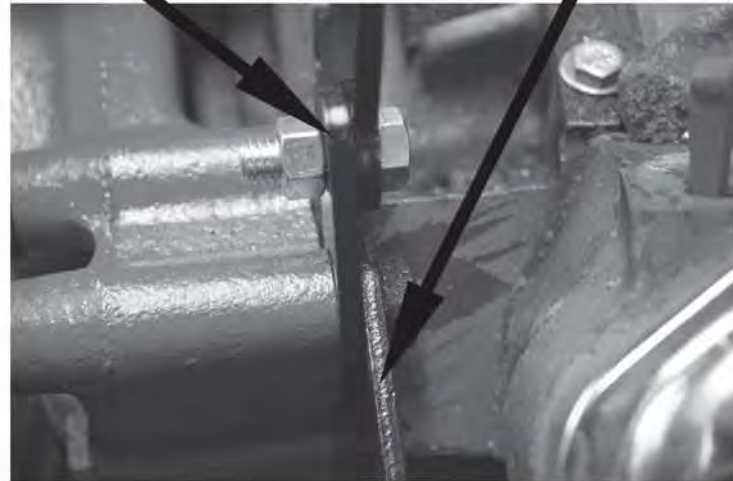

**IF USING P/S, USE 5/8" SPACER HERE IN PLACE OF
 3/4" SPACER.**

**NEW REAR BRACKET
PLATE BETWEEN
PUMP HOUSING &
P/S BRACKET**

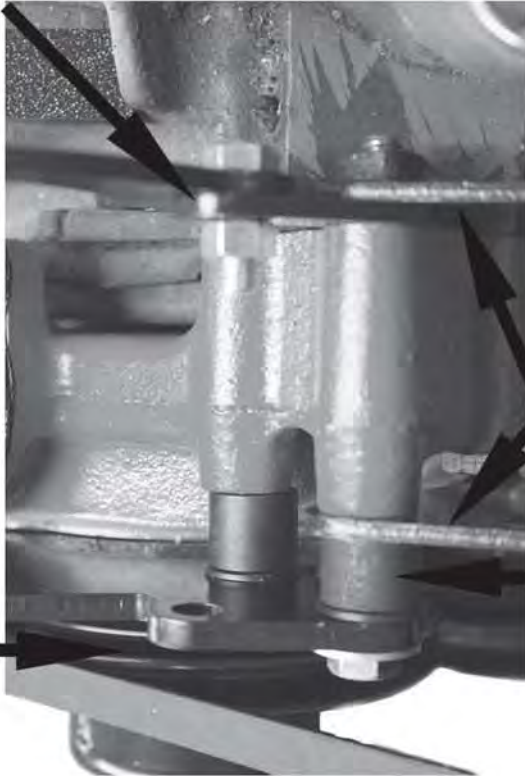

**NEW FRONT
BRACKET**

**FACTORY P/S
BRACKET**

**5/8" SPACER
HERE**

BRACKET SHOULD LOOK LIKE THIS ONCE INSTALLED

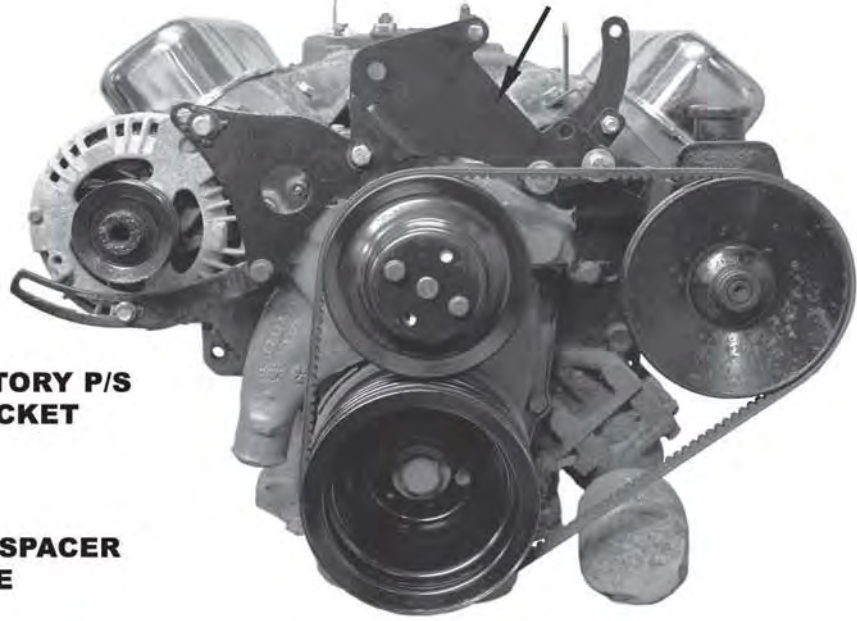

IF USING ALTERNATOR AND COMPRESSOR ON SAME BELT. INSTALL COMPRESSOR WITH THE LEGS ON THE BACK SIDE OF THE BRACKET.

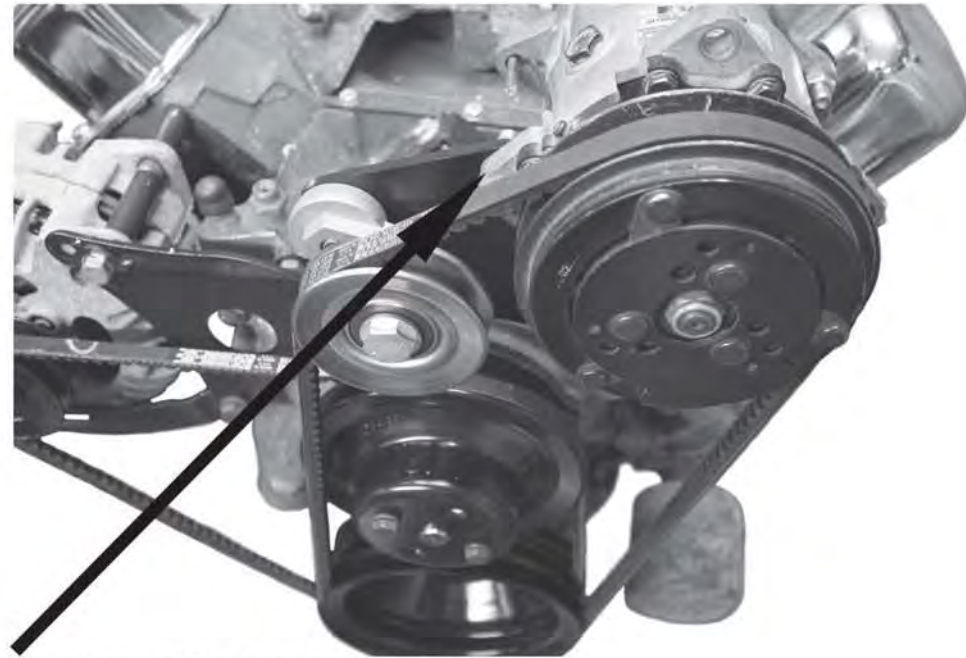

IF USING IDLER PULLEY. INSTALL COMPRESSOR WITH THE LEGS ON THE FRONT SIDE OF THE BRACKET.

**BRACKET SETUP WITH POWER STEERING.
THIS SETUP REQUIRES 2 GROOVE CRANK PULLEY AND POWER STEERING
SUGGESTED BELT SIZE #15585**

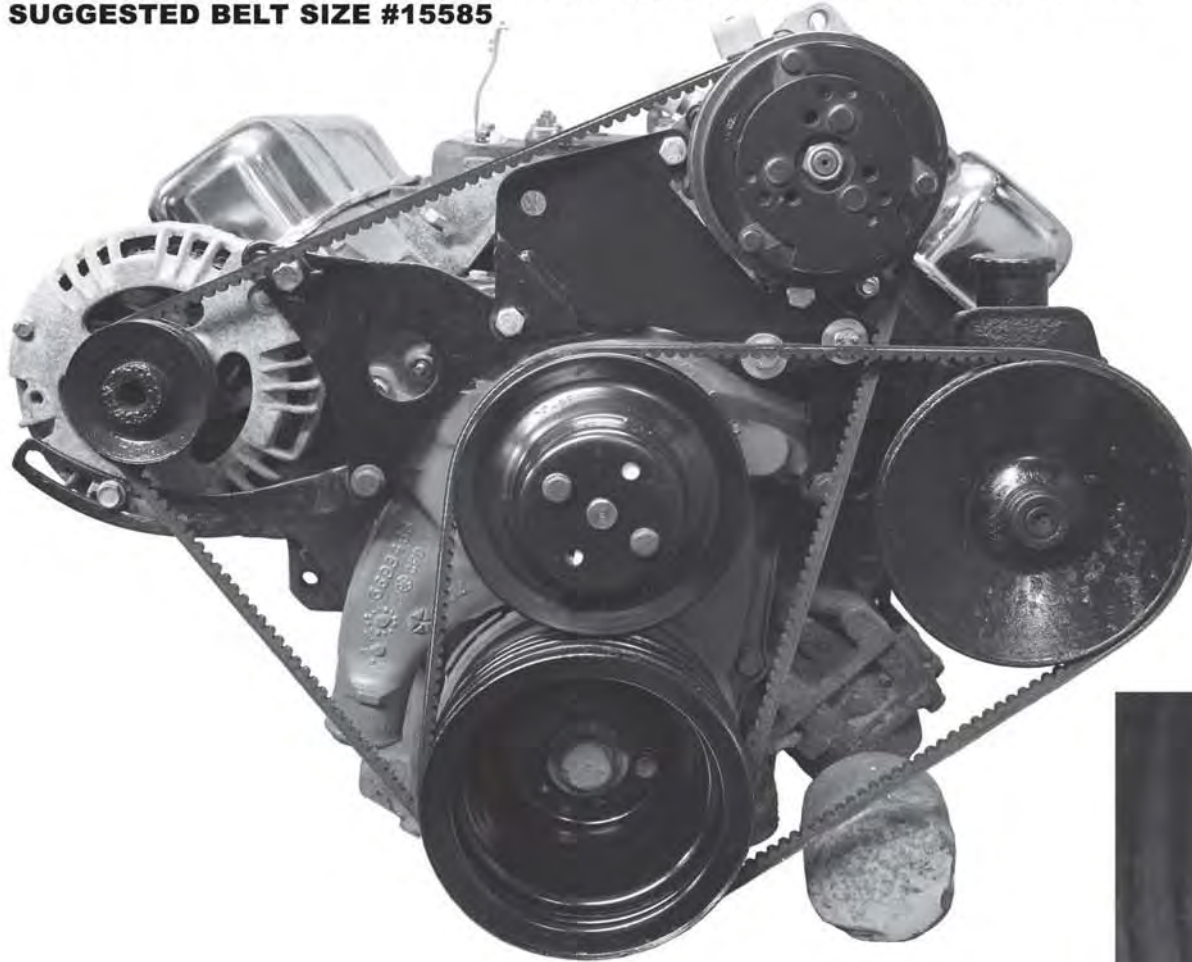

**BRACKET SETUP WITHOUT POWER STEERING.
THIS SETUP REQUIRES 3 GROOVE CRANK PULLEY 3-1/2" DEEP OR OUR ADD ON PULLEY PN:PM12
SUGGESTED BELT SIZE #50517**

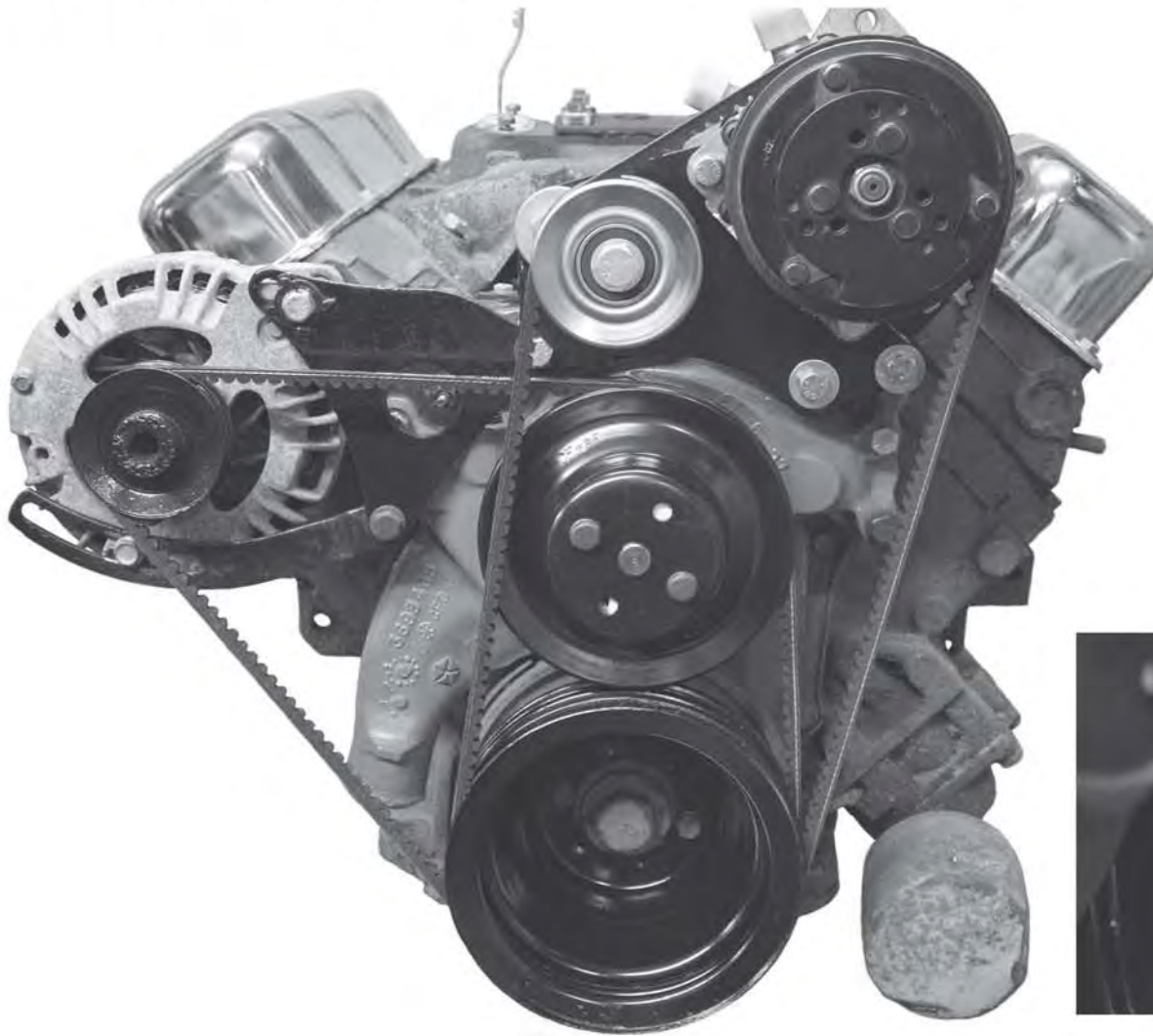



**BRACKET SETUP WITH POWER STEERING AND IDLER.
THIS SETUP REQUIRES 3 GROOVE CRANK PULLEY 3-1/2" DEEP OR OUR ADD ON PULLEY PN:PM12
SUGGESTED BELT SIZE #50517**

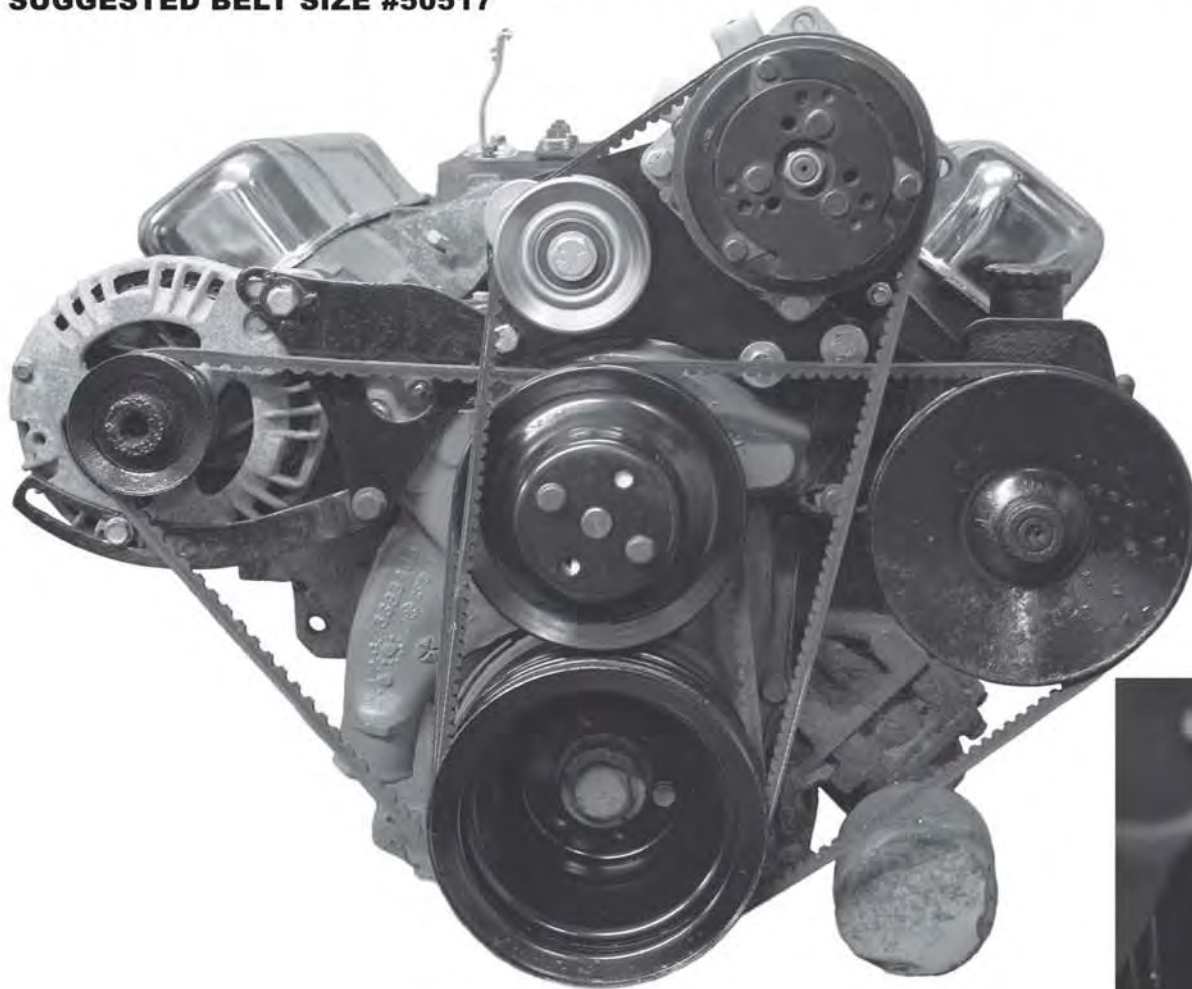

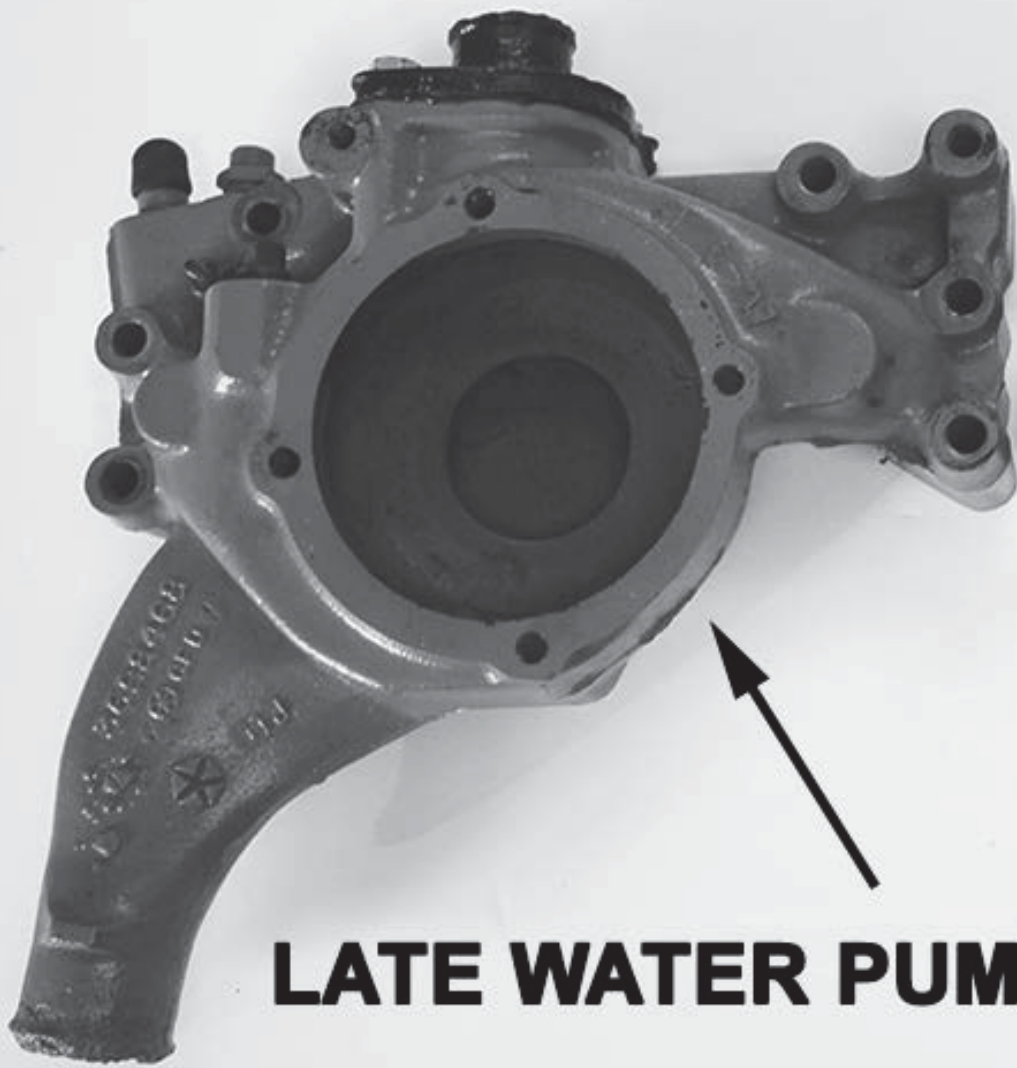

LATE WATER PUMP

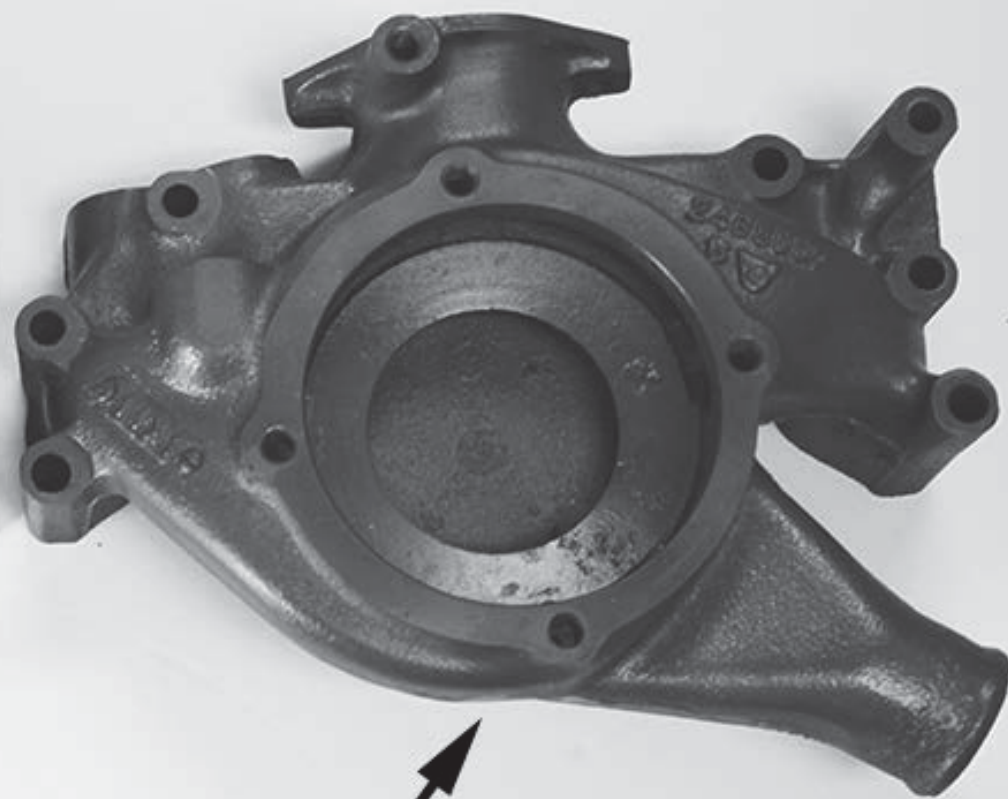

EARLY WATER PUMP